



Sieve and sifter certification
& inspection service.

Applicable industries:



Food



Agriculture



Pharma



Recycling



Plastics



Construction



Glass



Chemical



SPECIFICATIONS:



The **CENTAURO** is a compact, lightweight, and mobile sieve shaker. It is commonly used for control and safety sieving directly on-site, as it can be easily moved from one location to another. **It is suitable for both liquids and solids.**

It is used for products such as: glazes, paints, ceramic powder, sands, as well as in the chemical, food, or agricultural industries.

Our mobile circular sieve shaker is made of AISI-304 stainless steel. Upon request, it can also be manufactured in AISI-316. It supports a single sieving level, and the mesh is easily interchangeable.

➤ Available in diameters of 450 and 600 mm.

TECHNICAL DATA:



- Low maintenance and high versatility.
- Easy-to-install sieve.
- Trolley with adjustable height.
- Single working level.



TECHNICAL FEATURES:



	Voltage (V)	Current (A)	Power (Kw)	Freq.(Hz)	(r.p.m)	Weight (Kg)
FTIS-0450	380	0.41	0.155	50	1500	42
FTIS-0600		0.6	0.3			47

*Other voltages available upon request.



Product flow path adjustable via eccentric mass configuration.

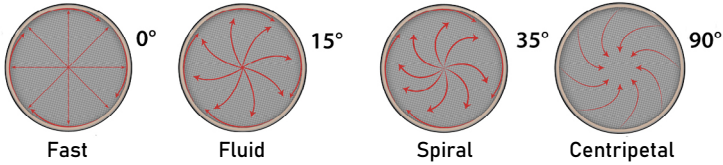

DIMENSIONS:

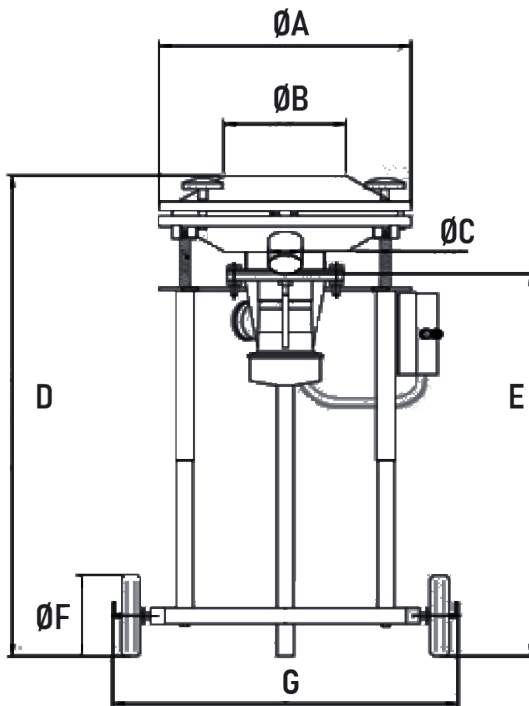

(mm)	FTIS-0450	FTIS-0600
ØA	300	400
ØB	402	500
ØC	480	575
ØD	1032	1175
E	361.5	398
F	100	100
G	630	650

OPTIONAL ACCESSORIES:



Mesh & sheet metal sieves



Steel lids



Ultrasound System

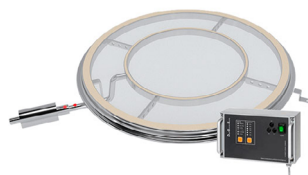

Bodies with/without outlets



Self-cleaning ring/food-grade rubber balls



Clamp with quick-release and spring

