



3D MOTION
ATEX UNDER REQUEST



VULCANO FTI-0300 | FTI-0400

The "Vulcano" Industrial Sieve shaker is ideal for small production runs of between 5 and 75 kg of product, liquids or solids, depending upon the type.

Manufactured from AISI 304 stainless steel (or AISI 316, under request), it features an imbalanced-weight motor which produces a three-dimensional motion - in the horizontal and vertical planes - which makes the sieving of the product as easy as possible. Adjustment of the imbalanced-weights allows the regulation of product behaviour on the mesh and the sieving speed.

The bottom has a side outlet through which the obtained product can be unloaded. The sieves can be ordered with or without product outlet. In the case of choosing a sieve with outlet, the sieving process can be automated: as the product enters the sieve it also leaves via the sieve opening.

This sieve shaker allows up to 5 sieves of 300 or 400 mm Ø. The fastening system comprises of threaded stainless rods, Bakelite knobs and an open (for feeding) or closed methacrylate ring.

As an option it can be fitted with an Easy-Press quick release coupling system or metal lid.

INCLUDES:

- > Circular sieve shaker.
- > Methacrylate lid.
- > Threaded closing system.
- > User manual.
- > CE declaration of conformity.



TECHNICAL FEATURES

	FTI-0300	FTI-0400
Voltage	380-400 V	380-400 V
Frequency	50-60 Hz	50-60 Hz
Speed	1500rpm	1500rpm
Current	0.34 A	0.6 A
Power	0.155 kW	0.300 kW

TECHNICAL DIMENSIONS

(mm)	FTI-0300	FTI-0400
A	ø 300	ø 400
B	402	500
C	480	575
D	1070	1260
E	400	480
F	ø 92	ø 92

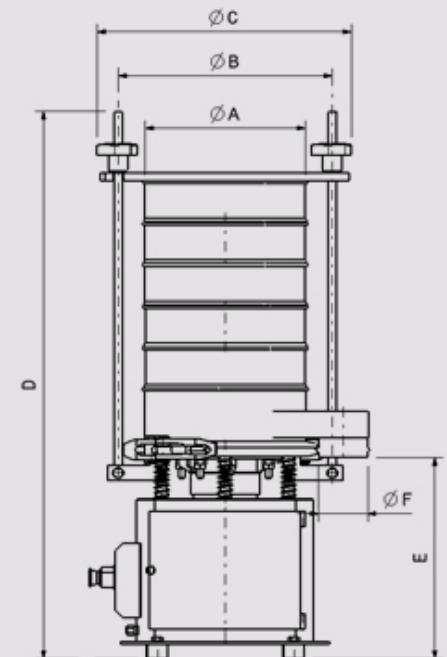

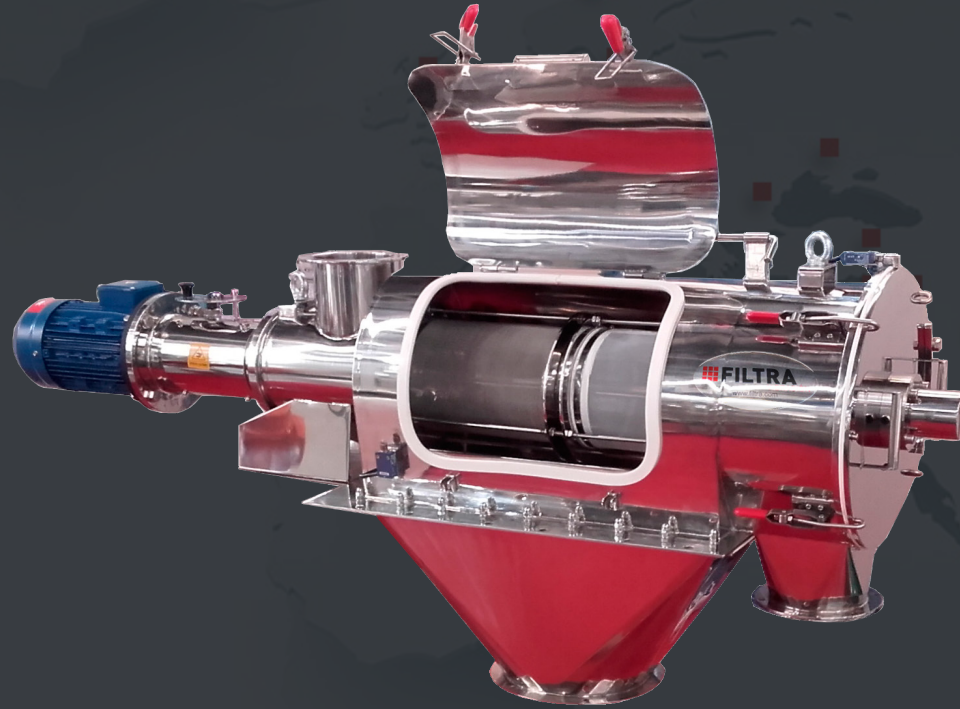

SIEVING FOR LABORATORY AND INDUSTRIAL PROCESSES

FILTRA
VIBRACIÓN

Filtra Vibración S.L

C/ BRONZE, 1-3, P.I. LES GUIXERES
08915 BADALONA (BARCELONA)

filtra@filtra.com
filtra.com